

Turnstile Pod System



AUTOMATIC METAL ROLLER SHUTTERS

Front and back, with manual over-ride for optimal security when site is closed

230V FEMALE COMMANDO SOCKET

LIFTING EYES

For efficient lowering into place by crane

The Secure Site Turnstile Pod System Includes:

- ✓ 1x metal turnstile pod incorporating full-height, bi-directional turnstile.
- ✓ 2 x Suprema BioEntry W2 vandal-proof IP67 fingerprint readers (the World's fastest).
- ✓ 1x Suprema BioMini Enrolment reader located in site office/induction room.
- ✓ 1x Dell PC, pre-loaded with Suprema Bio Star access control software, with no ongoing licence fee.
- ✓ 1x Mono printer and first toner cartridge.
- ✓ 1x Press to Exit (PTE) switch
- ✓ 1x Emergency egress button
- ✓ FOC on-line pre-enrolment and induction portal, for up to 50,000 users.



FULL HEIGHT METAL BI-DIRECTIONAL TURNSTILE

COMPACT DESIGN WITH 2.56m² FOOTPRINT

SUPREMA BIO ENTRY W2 FINGERPRINT READERS



Summary of Features:

- ✓ Full time and attendance reporting, with a complete employee database, hours and data for payroll and ability to see who's on site at any one time, from any connected PC.
- ✓ Quick enrolment (less than 3 minutes) based on qualifications and CSCS card validity. A report of CSCS cards due to expire within a certain period can also be generated to help ensure renewal in good time.
- ✓ Anti 'pass-back', meaning a user cannot help someone get onto the site by using their fingerprint a second time, so ensuring only valid contractors can gain site access.
- ✓ To comply with site H&S requirements, the muster report is immediately available to enable site managers or emergency services to quickly account for all operatives who were on site in the event of an evacuation.
- ✓ If integrated with your fire alarm system, activation of this acts as the input, with the system configured to automatically place the turnstile in free spin status. This allows contractors off the site as well as emergency services onto the site, without any hindrance.
- ✓ Should you want to, the fingerprint of the first person on site in the morning and last person to leave the site at night, can automatically disarm or arm your intruder alarm system, respectively.
- ✓ The software can link to your CCTV system to provide video evidence of an access control event.
- ✓ Product support and maintenance included.

Turnstile Pod Technical Specifications:

- Operating voltage: 230V
- Power consumption: 30W
- Tripod locking: with 24v solenoids
- Motion control: with hydraulic shock absorber
- Operating temperature: -20 C to 70°C
- Indicators: LED on both directions
- Turnstile finish: black powder coated
- Pod finish: graphite powder coated
- Weight: 810 kg
- Dimensions: 1580mmx1620mmx2650mm (wxdxh)
- Suprema W2 Fingerprint Reader: Vandal-proof IP67-rated, in durable metal housing and matching 100,000 fingerprints in 1 second (World's fastest)
- Suprema BioMini Enrolment Reader: incorporating the World's best performing fingerprint algorithm and scratch-free sensor.

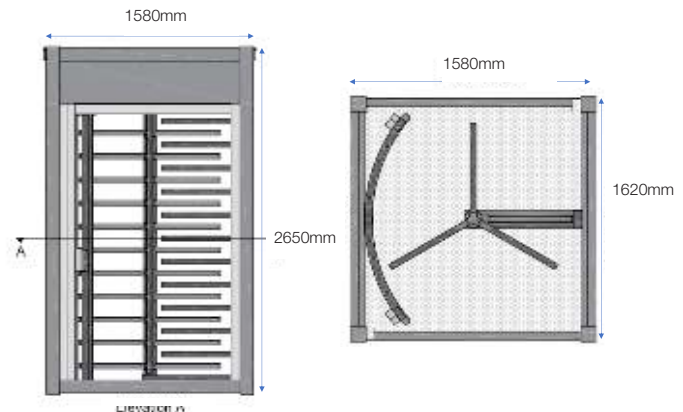

Includes:

**FREE
PRE-ENROLMENT
& INDUCTION
SOFTWARE**



Key Benefits:

- Ensures everyone aware of H&S requirements before stepping onto site.
- Simple to follow, step-by-step process on smartphone, tablet or PC.
- Confirms who to report to and when.
- Live dashboard confirms enrolment uptake to site management team.
- Saves considerable time, money and stress for site enrolment and H&S team.
- Just 3-minutes on site to validate CSCS card, photo ID and scan fingerprint.

SOUTHERN OFFICE

Head Office (Registered Office)
Units 1 & 2, Southdownview Works
12 Southdownview Road
Worthing, BN14 8NZ
Tel: 03331 23 13 12
Tel: 0333 123 13 12

MIDLANDS OFFICE

Unit C2
Sketchley Meadows
Industrial Estate
Hinckley, LE10 3EN
Tel: 03331 23 13 12
Tel: 0333 123 13 12

LONDON OFFICE

180 Piccadilly
London W1J 9HF
Tel: 03331 23 13 12
Tel: 0333 123 13 12



03331 23 13 12
www.securesiteuk.co.uk